



# Non-Sewered Sanitation Devices: A New ISO Standard for the Reinvented Toilet

**Edward R. Osann**  
**Natural Resources Defense Council**

**2020 Southwest Onsite Wastewater Conference**  
**Laughlin, NV**  
**January 30, 2020**



# Today's Presentation

- ▶ The imperative to “Reinvent the Toilet”
- ▶ Development of an ISO Product Standard
- ▶ Performance requirements in the ISO Standard
- ▶ Main technology paths
- ▶ Likely applications of NSSDs in North America
- ▶ Developing the regulatory framework

# The Global Sanitation Problem

- ▶ 1 in 10 people live without clean water – that's 844 million people
- ▶ 1 in 3 people, 2.3 billion, do not have regular access to a decent toilet
- ▶ 800 children under 5 die every day from diarrheal diseases caused by poor water and sanitation





“Improved sanitation contributes enormously to human health and well-being, especially for girls and women. We know that simple, achievable interventions can reduce the risk of contracting diarrheal disease by a third.”

WHO Director-General Dr. Margaret Chan





# This is an International Priority

## UN Sustainable Development Goals (2015)

- Goal 6. Ensure availability and sustainable management of **water** and **sanitation** for all
- “Access to safe water and sanitation and sound management of freshwater ecosystems are essential to human health and to environmental sustainability and economic prosperity.”

## 2017 WHO/UNICEF Joint Monitoring Programme Report

- “Universal implies all settings, not only to households, but also schools, health care facilities, workplaces and other public spaces.”
- “These limited sanitation services reflect both cultural practices and socioeconomic constraints in densely populated areas.”

# Understanding the Problem

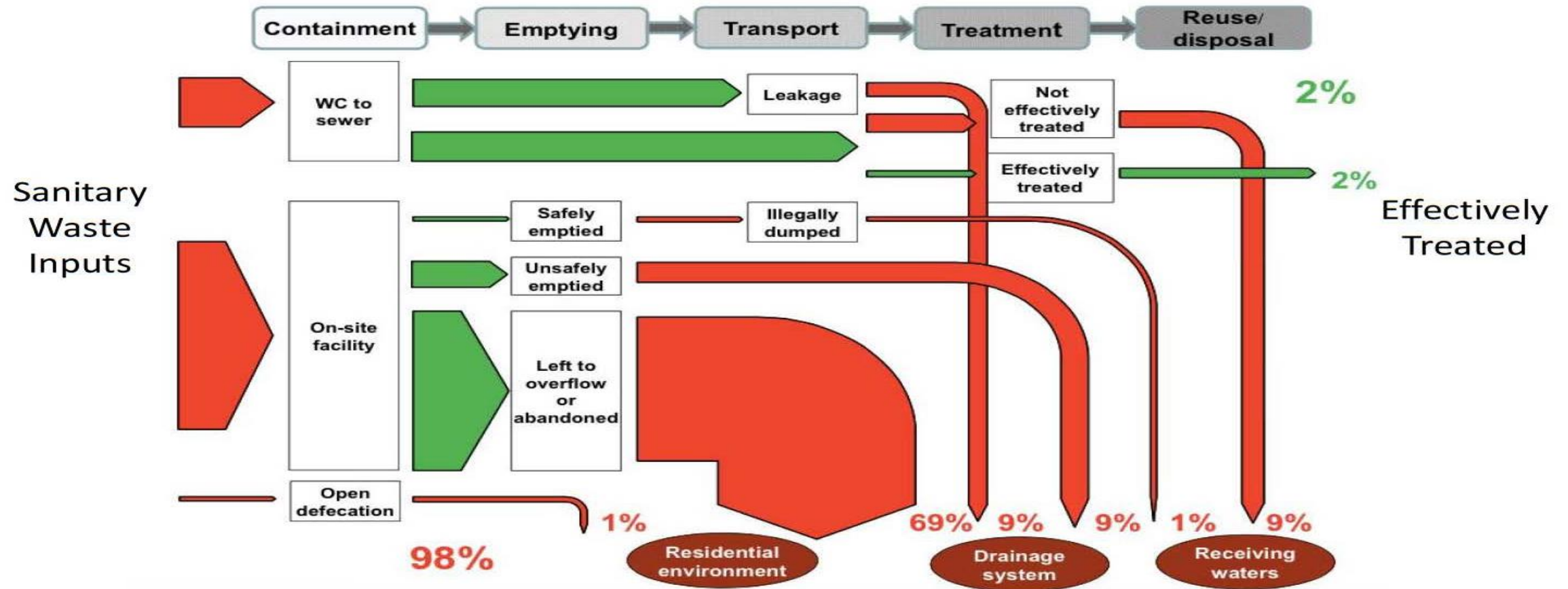

Dhaka, Bangladesh  
Population: 14.4 million

Ineffectively Treated

Source: SFD Promotion Initiative,  
Panesar, et.al., 2015



# The Extent of the Problem

## Kigali, Rwanda

- ▶ Population of over 1.1 million
- ▶ Lacks a sewer system
- ▶ 67% of its residents live in dense, unplanned areas
- ▶ Majority of those living in unplanned areas use pit latrines
- ▶ Most pits are emptied manually



# 2011: Gates “Reinvent the Toilet” Challenge

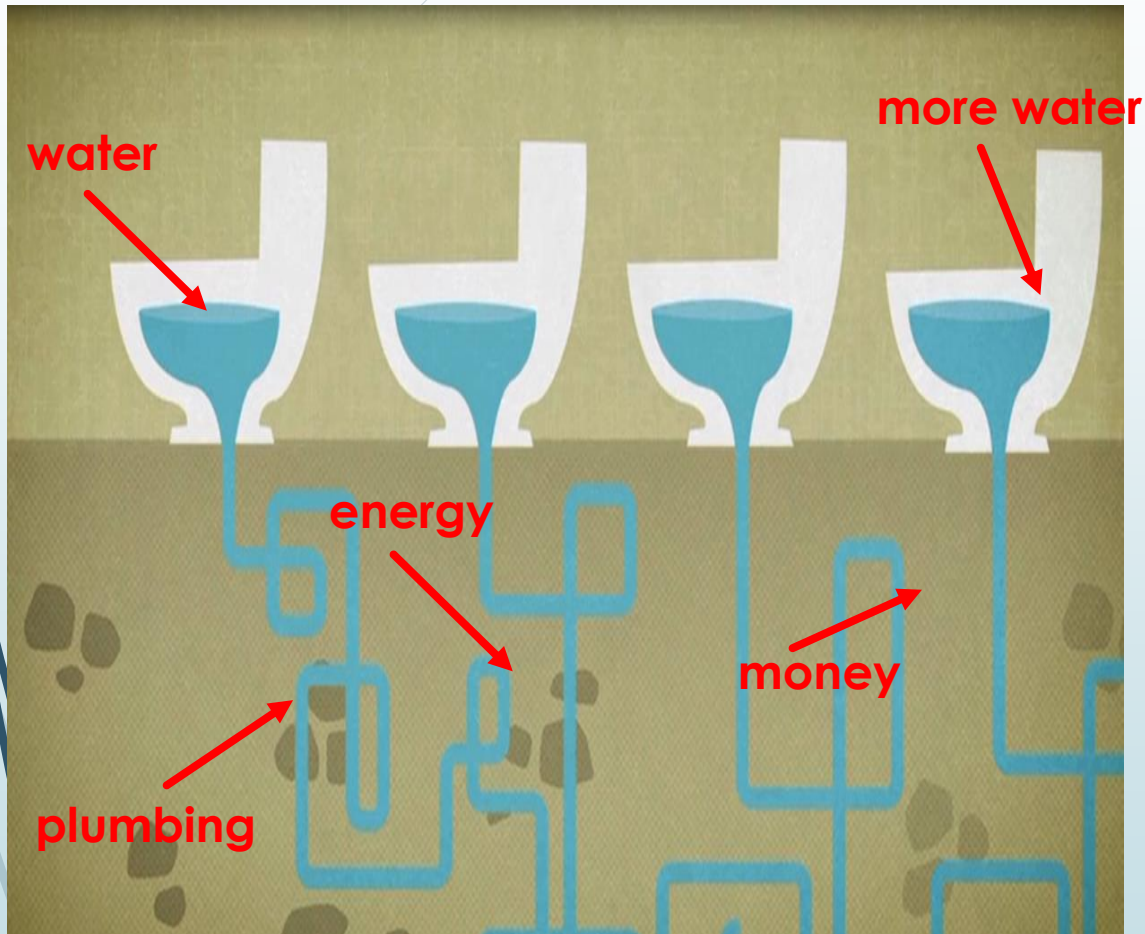

The Reinvent the Toilet Challenge aims to create a toilet that:

- ▶ safely eliminate or beneficially recover human waste,
- ▶ works off the grid,
- ▶ costs less than 5 cents per user per day,
- ▶ promotes sustainable and financially profitable sanitation services and businesses that operate in poor, urban settings, and
- ▶ is a truly aspirational next-generation product that everyone will want to use.





# Gates' Grantees for “Reinvent the Toilet” Initiative

- Groups and Principal Investigators:

- California Institute of Technology – Mike Hoffman
- Cranfield University – Ewan Mc Adam
- Loughborough University – M. Sohail
- RTI International – Brian Stoner
- University of South Florida – Daniel Yeh
- University of Toronto – Yu-Ling Cheng
- University of West England, Bristol – Ioannis Ieropoulos
- Eawag – Tove Larsen

- All have published literature (all open access papers)

# The Value of a Product Standard



- ▶ Provides a clear roadmap for researchers, product manufacturers, and marketers.
- ▶ Provides specific guidance for procurement by large purchasers
- ▶ Instills confidence in government regulators to permit the sale and installation of such products in their jurisdiction
- ▶ An international standard offers potential scale economies for manufacture and distribution of compliant products
- ▶ Voluntary, unless or until made mandatory by government action

# From Concept to ISO Standard



- 2014-2015: Bill & Melinda Gates Foundation private standard development
- May 2016: ISO International Workshop Agreement (IWA 24:2016): Singapore
- Sept 2016: ISO Project Committee 30500 organized: Washington
- May 2018: Final ISO PC 30500 plenary: Katmandu
- Oct 2018: ISO 30500 published
- Dec 2019: US & Canadian national adoption, designated ANSI/CAN/IAPMO/ISO 30500-2019



# What is a non-sewered sanitation system (NSSS) under the ISO Standard?

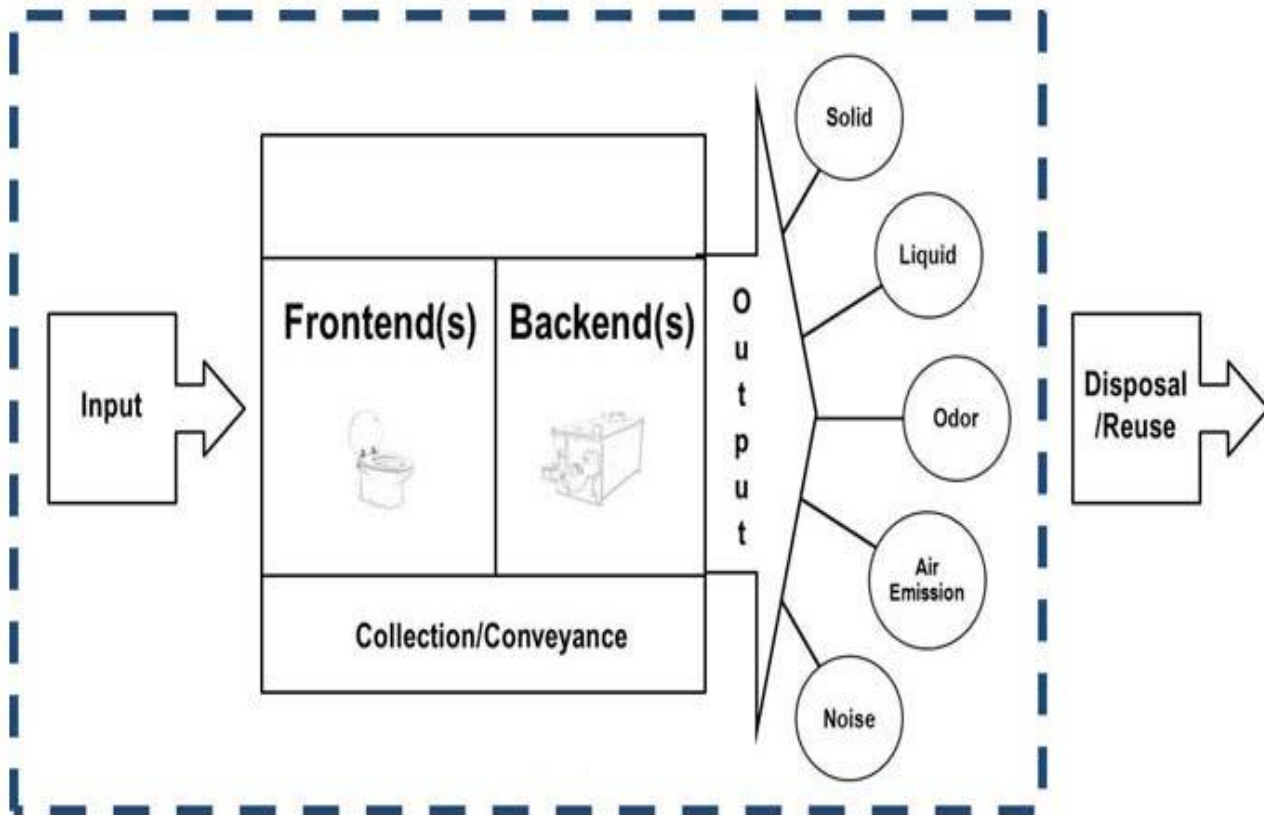
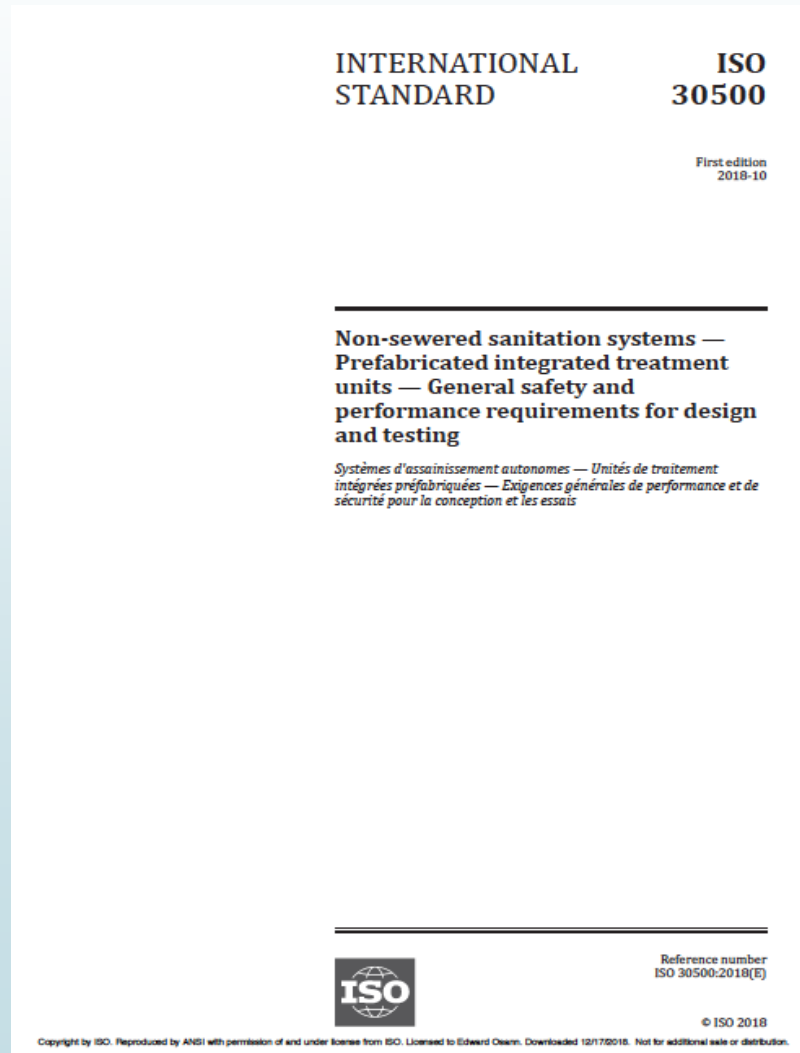

Figure 1: Scope of standard

- NSSS: A device that isn't connected to a sewage system and collects and fully treats the input (human excrement) into a safely reusable or disposable output
- Packaged, not site-built
- How do they work?
  - combustion
  - electrochemical reactions
  - biological treatment
  - combinations of the above

# ISO 30500 : Performance Requirements and Test Procedures



- ▶ Product definition
- ▶ Performance Requirements:
  - ▶ Solid output and effluent
  - ▶ Odor
  - ▶ Noise
  - ▶ Air emissions
- ▶ Requirements for components and materials
- ▶ Requirements for safety and reliability
- ▶ Test procedures
- ▶ User interface requirements

# ISO 30500 :Performance Requirements for Solid Output

**Table 4 — Solid output validation thresholds and log reduction values (LRVs) for human health protection**

Parameter (Pathogen class)	Human enteric bacterial pathogens	Human enteric viruses	Human enteric Helminths	Human enteric Protozoa
Surrogate	using <i>E. coli</i> <sup>b</sup> as surrogate, measured in CFU or MNP	using MS2 Coliphage as surrogate, measured in PFU	using <i>Ascaris suum</i> viable ova as surrogate	using viable <i>Clostridium perfringens</i> spores as surrogate, measured in CFU
Max. concentration in solids [number/g (dry solids)]	100	10	< 1	< 1
Overall LRV for solid <sup>a</sup>	≥ 6	≥ 7	≥ 4	≥ 6

<sup>a</sup> Log-reduction values (LRVs) were derived from a quantitative microbial risk assessment (QMRA) as described by WHO 2016, assuming 1 g of faecal solids contains approximately the same range of reference pathogens as in 1 l of liquid effluent (for LRVs derived in [Table 5](#)). For further information, see Reference [61] and Reference [72].

<sup>b</sup> *E. coli* strain KO11 (ATCC 55124) is selected because it is chloramphenicol resistant. Therefore, this antibiotic may be added to the plating medium to suppress the growth of other, interfering bacteria.



# ISO 30500 : Performance Requirements for Liquid Effluent

**Table 5 — Liquid effluent validation thresholds and log-reduction values (LRVs) for human health protection**

Parameter (Pathogen class)	Human enteric bacterial pathogens	Human enteric viruses	Human enteric Helminths	Human enteric Protozoa
Surrogate	using <i>E. coli</i> <sup>b</sup> as surrogate, measured in CFU or MPN	using MS2 Coliphage as surrogate, measured in PFU	using <i>Ascaris suum</i> viable ova as surrogate	using viable <i>Clostridium perfringens</i> spores as surrogate, measured in CFU
Max. concentration in liquids (number/l)	100	10	< 1	< 1
Overall LRV for liquid <sup>a</sup>	≥ 6	≥ 7	≥ 4	≥ 6

<sup>a</sup> Log-reduction values (LRVs) were derived from a quantitative microbial risk assessment (QMRA) as described by WHO 2016. For further information, see Reference [61] and Reference [72].

<sup>b</sup> *E. coli* strain KO11 (ATCC 55124) is used because it is chloramphenicol resistant. Therefore, this antibiotic may be added to the plating medium to suppress the growth of other, interfering bacteria.

# ISO 30500 : Performance Requirements for Effluent – Environmental Parameters

**Table 6 — Effluent performance thresholds for environmental parameters**

	<b>Category A usage: Threshold for unrestricted urban uses</b>	<b>Category B usage: Threshold for discharge into surface water or other restricted urban uses</b>
COD (mg/l)	≤ 50	≤ 150
TSS (mg/l)	≤ 10	≤ 30

**NOTE 1** In accordance with Reference [81], Category A usage refers to unrestricted urban uses that comprise all uses where public access is not restricted (e.g. landscape irrigation, toilet flushing).

**NOTE 2** In accordance with Reference [81], Category B usage refers to discharge into surface water and other restricted urban uses that comprise all uses where public access is controlled or restricted by physical or institutional barriers (e.g. fences, temporal access restriction).

**NOTE 3** COD refers to total COD unfiltered.

# ISO 30500 : Performance Requirements Environmental Parameters (cont'd)

**Table 7 — Effluent performance load reduction percentage for nutrients (Environmental requirement)**

	<b>Minimum load reduction percentage</b>
	<b>%</b>
<b>Total nitrogen</b>	<b>70</b>
<b>Total phosphorus</b>	<b>80</b>

**Table 8 — Effluent performance range for pH (Environmental requirement)**

	<b>Range for all reuse purposes</b>
<b>pH</b>	<b>6 to 9</b>



# ISO 30500: Air Emission Requirements

**Table 11** — Indoor air emission thresholds

Parameter and Emission thresholds (average levels over indicated timeframe)

- ▶ CO (ppmv) 1 h: 28
- ▶ NO<sub>x</sub> (ppbv) 1 h: 99
- ▶ SO<sub>2</sub> (ppbv) 1 h: 6.8
- ▶ CO<sub>2</sub> (ppmv) 1 h: 1 000
- ▶ H<sub>2</sub>S (ppbv) 30 min: 4.6
- ▶ VOCs (ppbv) 1 h: 187
- ▶ PM<sub>2,5</sub> (µg/m<sup>3</sup>) 1 h: 25
- ▶ NH<sub>3</sub> (ppmv) 1h: 25

**Table 12** — Outdoor exhaust or vent air emissions thresholds

Parameter and Emission thresholds (1 h average)

- ▶ CO (ppmv) 80
- ▶ SO<sub>2</sub> (ppmv) 68
- ▶ NO<sub>x</sub> (ppmv) 195
- ▶ VOC (ppmv) 12
- ▶ H<sub>2</sub>S (ppmv) 1.9
- ▶ PAH (ppmv) 0.001
- ▶ PM<sub>2,5</sub> (mg/m<sup>3</sup>) 10
- ▶ NH<sub>3</sub> (ppmv) 50



## Other Key Requirements

- Odor – Using pre-screened panelists, a max of 10% of reports are rated “unpleasant” and a max of 2% are “unacceptable”
- Noise – an average of 60 dbA over 24 hrs and a max of 85 dbA at any time
- Visibility – No visibility of any accumulation of feces from previous users
- User manual – required, along with any specialized tools needed for maintenance
- Maintenance – product designed to allow users without technical expertise to perform routine user maintenance



# ISO 30500: Test Procedure Overview -- Laboratory and Field Testing Required

## Laboratory Testing

- ▶ 32-day test period
- ▶ Use of actual human waste, spiked as necessary with surrogates for human pathogens
- ▶ Normal loading and challenge loading
- ▶ Includes stop and start sequences simulating usage patterns
- ▶ Energy shut-off
- ▶ Overload protection

## Field Testing

- ▶ 30 days for non-biological systems
- ▶ 5 months for biologically-based systems
- ▶ Input to be collected and analyzed for one week in advance of testing for reference
- ▶ Tested weekly while in actual use by intended users
- ▶ Testing for three pathogens: helminth requirements deemed met by protozoa requirements

## Two versions of Reinvented Toilet for different scales: single and multi unit



### Single unit (SURT)

A single toilet and attached processing unit that fully treats solid waste and wastewater

*Capacity:* ~1-2 households

*Example use cases:* household, small commercial building



### Multi unit (MURT)

Central processing unit that connects to multiple toilets to treat waste and recycle wastewater for flushing

*Capacity:* Varies, up to ~500 users

*Example use cases:* apartment building, public toilet block



# 22 core processing technologies

## ➤ ELECTROCHEMICAL



## ➤ WET OXIDATION



## ➤ DRY COMBUSTION

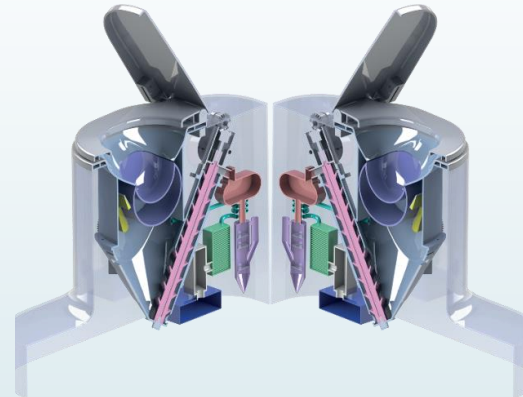

## ➤ BIOLOGICAL

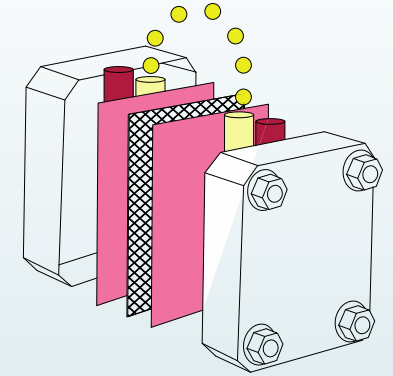

Caltech

helbling

eawag  
aquatic research ooo



UNIVERSITY OF  
TORONTO



Cranfield  
UNIVERSITY



USF UNIVERSITY OF  
SOUTH FLORIDA



Stanford  
University

COLUMBIA UNIVERSITY  
IN THE CITY OF NEW YORK

# The Caltech Toilet: treats and recycles wastewater for reuse as flushing water

SYSTEM COMPONENTS

- 1. Frontend** User interface containing toilets and urinals
- 2. Urine/Feces Separation** Passive settling and anaerobic digestion occurs
- 3. Liquid Processing** Electrochemical process treats urine and wastewater and produces hydrogen. Table salt (Chloride) is oxidized, increasing disinfection.
- 4. Solids Processing** Solids are macerated and the suspended fraction is treated with the liquids. Settled solids are evacuated once a year.
- 5. Power System** Solar panels with energy storage in batteries and/or grid electricity.

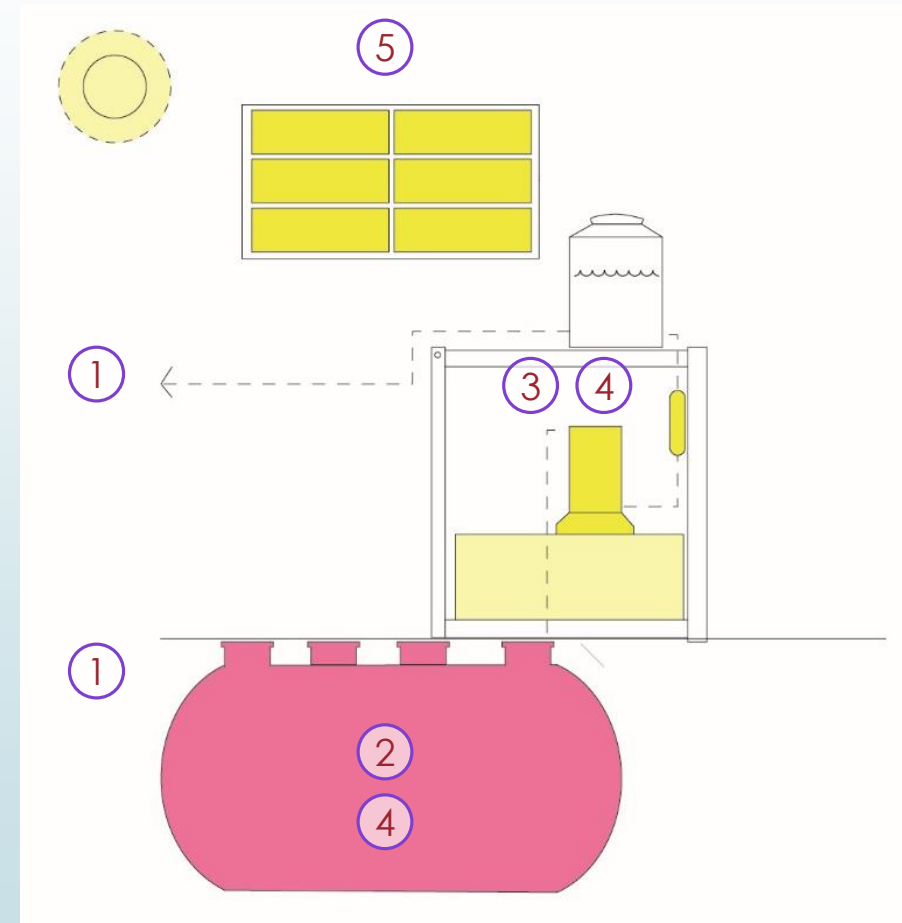

# Caltech Electrochemical toilet | details

24

## Use Cases: *MURT*

- Scalable; capable of servicing 50-800 users per day with one system.

## Key Features:

- Unique electrochemical cells process mixed wastewater
- Process effluent can be reused as toilet flush water.
- Compatible with any type of flush toilets (squat pan, western style, etc.)
- At least one commercial partner prototype can be fully containerized

## Commercialization: *Partnerships with large and small companies, open to additional partnerships*

- Patents pending in the United States, India, and China. See WO 2014/058825 A1 for further information.
- Test licenses in place with multiple commercial partners with path to commercial license. No commercial licenses negotiated to date.

**Learn More:** <http://hoffmann.caltech.edu/>

2017 EcoSan prototype of public toilets (*MURT*), also available in a fully containerized solution.



Earlier prototype of the CalTech technology

# The Toronto system uses combustion

## 1. Frontend

Currently used with an elevated squat plate that is above backend components

## 2. Urine/Feces Separation

Liquids and solids are separated. This separation device is built into the squat plate, just below the user interface

## 3. Liquid Processing

Sand filter captures solids particles and parasites. UV light kills pathogens in the filtered liquid. Sand is transferred to smoldering chamber for combustion with the other solids.

## 4. Solids Processing

Solids flattened and dried, then transferred into a smoldering chamber for combustion. Combustion will destroy pathogens, and byproducts are filtered to remove odors

## 5. Power System

TBD but options include solar panels and a thermoelectric generator

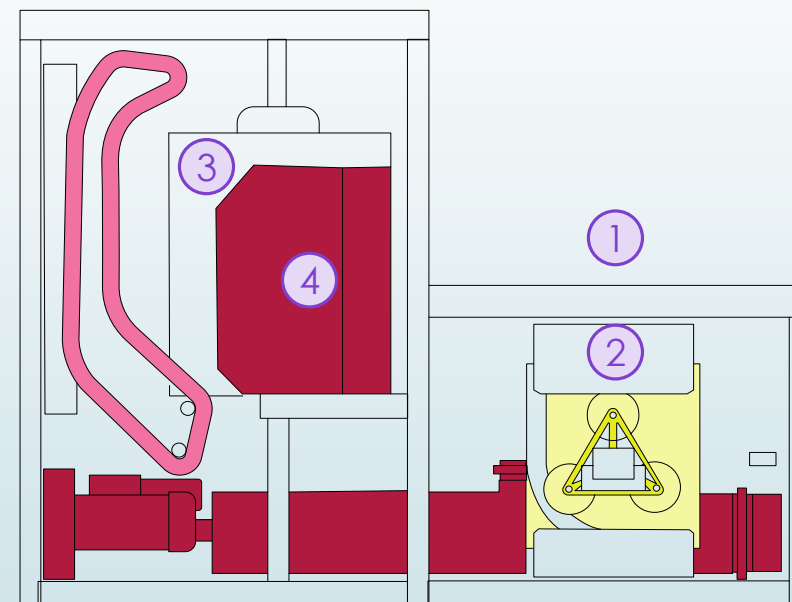



## The Toronto toilet | details

26

### Use Case: **SURT – household and community**

- Initially household toilet design: 10 users per day.
- Could be scaled-up for family application at 15-20 users per day, with potential for community (multi-stall) application with one system per stall.

### Key Features:

- Continuous smoldering process for processing of fecal matter and consistent heat production.
- Catalytic conversion of the generated pyrolysis gases supplies additional heat, and mitigates emissions.

### Commercialization: **Available for licensing and actively seeking commercial partners; Preserving IP rights for future corporate partner engagement**

- Provisional patent filed for solids processing.
- Initial discussions started with at least one commercial partner for household applications

**Learn More:** <http://cgen.utoronto.ca/research-initiatives/current-projects/re-invent-the-toilet-challenge/>



*Engineering prototype installation in India in mid-2017.*

## UWE Bristol microbial fuel cell (MFC) | biological

27

The Microbial Fuel Cell (MFC) generates electricity by processing urine. It is small enough to be built into a urinal, and multiple MFCs can be linked together in a “stack” to process greater volumes and increase power output. Compared to a traditional MFC this technology uses a ceramic as it’s membrane. While the power generation is typically the output expected from MFCs, this technology acts as a platform to produce disinfectant solutions (ECAS), fertilizers, and is being explored as a route for denitrification and nutrient removal from urine.

### How does it work?

#### 1. Frontend

The MFC is a backend processing component that can be integrated with a urinal or solids-liquids separating interface.

#### 2. Urine/Feces Separation

No separation of components, separation must occur upstream of the MFC.

#### 3. Liquid Processing

Organic compounds and pathogens in urine are consumed by a microbial community in the MFC, generating redox reactions. This enables movement of protons through a proton exchange membrane, and causes exchange of electrons between the electrodes generating current.

#### 4. Solids Processing

Can process a small concentration of solids at a low Total Suspended Solids (TSS). Has been demonstrated to kill pathogens.

#### 5. Power System

MFCs generate net power.

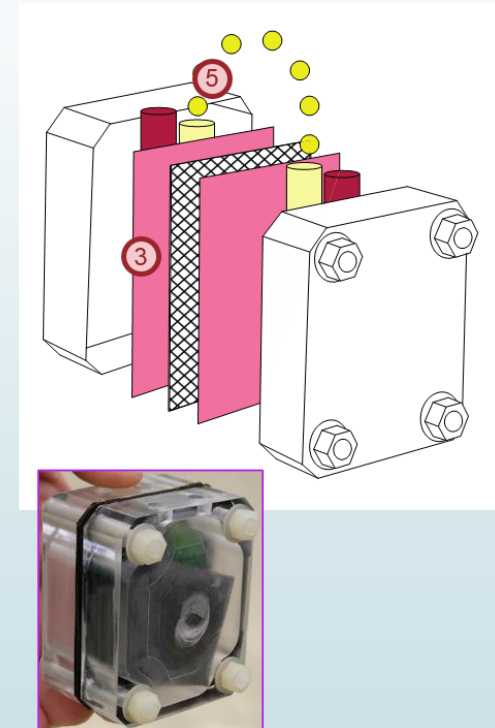

# UWE Bristol microbial fuel cell (MFC) | details

28

## Use Cases: MURT or SURT

- System is scalable; multiple MFC cells can be stacked to accommodate large volumes

## Key Features:

- System design is a small, cubicle cell.
- System produces electricity via breakdown of microbes and organic compounds in urine.
- Novel, cheap membranes improve cost effectiveness. It has been demonstrated that at certain scale membranes are not needed.
- Generates a byproduct which can be used as a disinfectant

## Commercialization: IP filed, actively seeking commercial partners

- Patent pending in the United States, Great Britain, China, and Japan, with additional EU designation pending. See US 2014/0057136 A1 for additional detail.

**Learn More:** <http://www.brl.ac.uk/researchthemes/bioenergyself-sustaining.aspx>



V1. Pee Power toilet with stack of MFCs underneath. Lights of the toilet were powered



Ceramic membrane prototype.

# Cranfield Nanomembrane Toilet | Dry combustion

29

Fully self-contained household toilet system. Frontend resembles a Western-style pedestal toilet, and all processing components are housed within. In the backend, solids and liquids are settled. The solids are extracted by a specifically designed auger, dried, and combusted, while liquids are preheated and purified through a dense membrane by pervaporations.

## How does it work?

1. Frontend

User encounters a pedestal toilet with a unique waterless flush system. A rotating odor barrier and scraper mechanism manages odor and enables dry flushing.
2. Urine/Feces Separation

Solids and liquids are separated by gravity sedimentation. Liquids flow over a weir to liquids processing, while the solids are extracted using an auger.
3. Liquid Processing

A dense, nanomembrane separates clean water and volatile organics from the contaminated urine. The non-potable, clean water is then sent to a storage tank for later use.
4. Solids Processing

Solids are dried, pelletized and gasified to resulting in ash. The gasifier is being developed in partnership with other institutions, and is a micro-gasifier that can be fed at <math>< 1 \text{ g/min}</math> of dried fecal waste.
5. Power System

The lifting of the toilet seat creates energy that is stored to eventually power the mechanical systems. Excess heat from the gasifier is used in the liquids disinfection process and potentially for power generation.

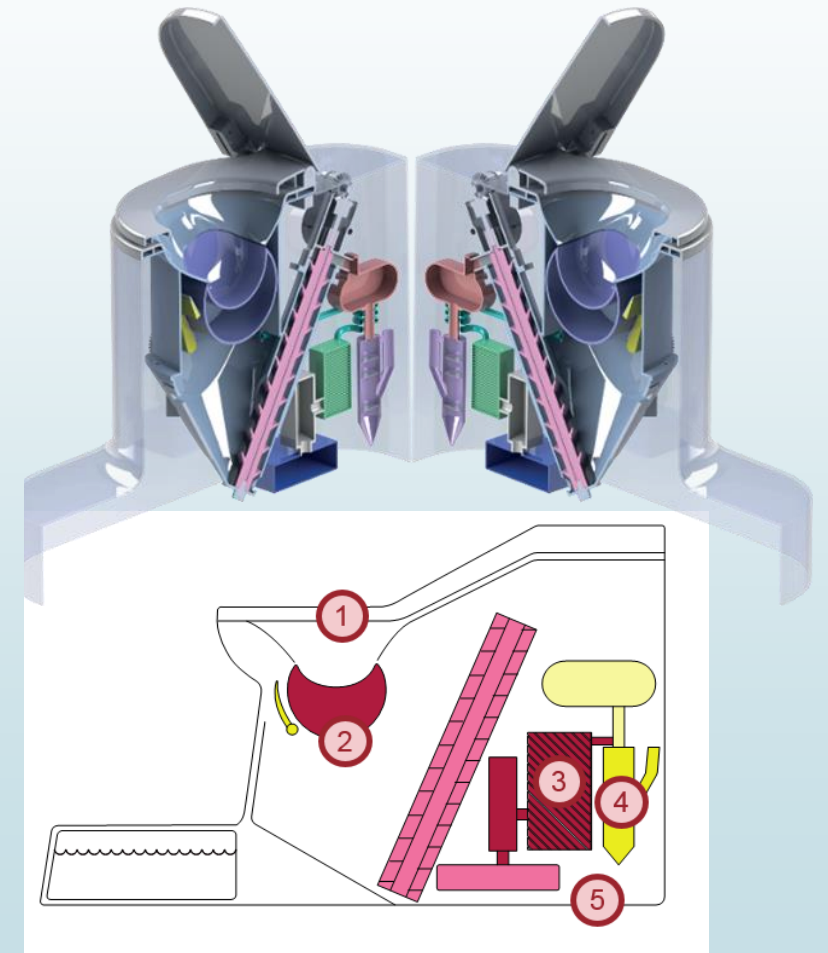



# Cranfield nanomembrane toilet | details

30

## Use Cases: *SURT, potential for MURT*

- Currently designed as a self-contained, household unit serving up to 10 users, but modeling has shown that core processing technology could be scaled.

## Key Features:

- System design is completely self-contained, no water or power connections are required
- Unique waterless flush system minimizes water requirements
- Heat from the gasification process is used to increase filtration efficiency
- System produces non-potable water each day for household use
- Ash requires regular disposal

## Commercialization: *Available for licensing and actively seeking commercial partners; Preserving IP rights*

- Multiple patent applications filed but not yet published

**Learn More:** <http://www.nanomembranetoilet.org/>



*Early Cranfield prototype on display at New Scientist Live in London; September 2016.*

# Potential Applications in North America



- ▶ National and provincial/state parks and forests
- ▶ Mobile sanitation for public event venues – festivals, concerts, etc.
- ▶ Rural/low density populations in
  - Arid lands
  - Poorly drains soils
  - Permafrost areas
- ▶ Any jurisdiction prone to water curtailment or sewage treatment capacity constraints
- ▶ Any home not served by central collection and treatment



# ISO 30500-Compliant Systems: Addressing Septic System Limitations



Removes blackwater from the waste stream --

- Fecal solids removed
- Fecal pathogens removed
- Hydraulic loading from toilets removed

Extends service interval

# “Known Unknowns”



- Availability
- Price
- Warranty
- Consumer acceptance
- Servicing requirements
- Repair history
- Business model for sales and installation
- Business model for maintenance and replacement



# Next Steps Toward Commercialization



- Build out a testing and certification infrastructure
- Getting model building and plumbing codes RT-ready
- Identifying demonstration sites and stakeholders in the US
- Encouraging state agency leadership (3 to 5 states) in policy development
- Developing model language for health agency permitting, by use case.



Thank You

Ed Osann [eosann@nrdc.org](mailto:eosann@nrdc.org)

Joelle Wirth [joellew86004@msn.com](mailto:joellew86004@msn.com)